

74 SERIES

Single Cartridge Housing

The **74 Series** single cartridge housing is available for elements up to 30" long. The plenum style configuration is ideally suited to both liquid and gas processes for pressures up to 10 bar g.

Mounted inline, this plenum styled housing will suit processes where there is a need to allow easy access to all internal areas, therefore assisting in the general cleanliness of the process system in which the filter is to operate.

Having no loose internal components ensures easy and fast clean down procedures.

The **74 Series** housing will accept the Single Open End Code 7 cartridge with nominal lengths of 10, 20 and 30".

Product Features

- Inline style construction with optional specification finish
- Cast Vee clamp closure for ease of access
- No loose internals for trouble free operation
- Easy drain plenum feature for gas applications
- PED and ATEX compliant
- CE Marked

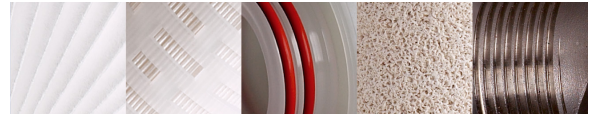

F Vent

G Vent

H Vent

J Vent

R Vent

S Vent

Features and Benefits

- Standard single open end cartridge fitting, using the Bayonet lock code 7 for forward and reverse flow
- 316L construction for maximum corrosion resistance.
- Every housing is etched with a serial number for full traceability.
- Wide range of options available for connection size, style and cartridge lengths.
- Full certification available, PED and ATEX compliant, CE Marked

Product Range

Amazon Filters design and manufacture an extensive range of liquid filtration systems, providing one of the widest selections of filtration vessels, depth filters and pleated cartridges available today, ensuring excellent process and filter compatibility. As one of Europe's leading manufacturers of filtration systems, Amazon Filters is able to offer a solution to meet all filtration requirements. Amazons' filters are manufactured in clean room conditions and all products come with detailed Product Validation Guides and Technical Support documentation.



74 Series Technical Data

Maximum Operating Conditions

Pressure Range: Liquid: FV / 10 bar g
 Temperature Range: -10°C / 150°C

Materials of Construction

Body and Closure: 316L St. Steel
 Clamp: 304 St. Steel

Finish

Vessel: Bead blast and electropolish

Connections

Inlet/Outlet: 1½" Hygienic Coupling
 Vent: ¼" BSPF
 Drain: ¼" BSPF

Model	Dimensions					Volume (Litres)	Dry Weight
	A	B	C	D	E		
74011XF15N1GE	436	68	-	249	350	3.8	5.2
74012XF15N1GE	691	68	-	249	600	5.7	6.5

PED Status:

Compliant with 2014/68/EU
 Gas Group 2
 Liquids Group 1 + 2

Marking:

CE - 20" (Gas Group 2)
 (SEP) Sound Engineering Practice - 10"
 (Gas Group 2)

Exceptions:

Group 1 liquids - Explosive

ATEX:

Compliant with 2014/34/EU, level CE Ex II 2 GD c X

Technical drawings for each individual housing showing dimensions, volume, weights, maximum temperatures and design pressures available on request.

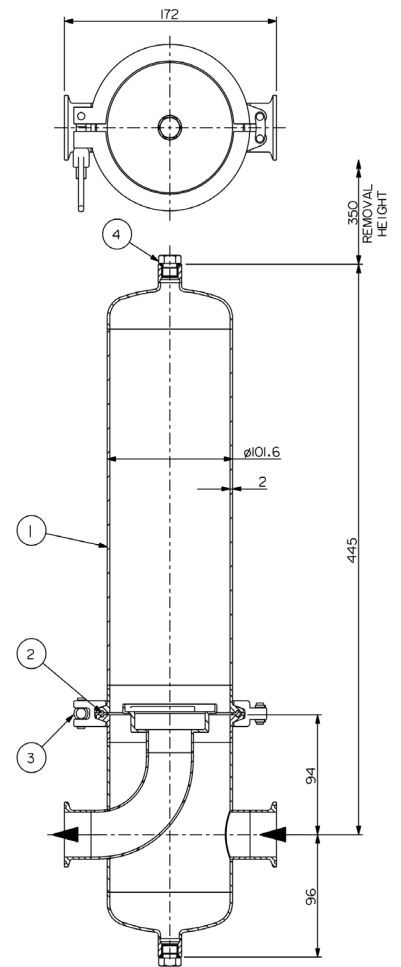

AMAZON FILTERS LTD.

ALBANY PARK ESTATE, FRIMLEY ROAD
 CAMBERLEY, SURREY, GU16 7PG
 ENGLAND

Tel. +44 (0) 1276 670600

Fax. +44 (0) 1276 670101

Email. sales@amazonfilters.co.uk

Web. www.amazonfilters.com



WWW.BETA-INDUSTRIE.NL
 TEL: 0031-79-3415518