

65 SERIES

3-10 Round Cartridge Housing





The **65 Series** housing range is designed to accommodate 3, 5 or 10, stacks of filter cartridges up to 40" long. These top opening style housings are secured with screw clamps as standard and suitable for pressures up to 16 bar g in liquids and between 1.5 and 16 bar g in gases. They are also suitable for full vacuum operation and processes between -10 and 150°C.

The housings are leg mounted and equipped with the more conventional dished end, therefore suit processes where there is a need to allow complete drainage of the clean chamber. This design assists in maintaining the general cleanliness of the process system. With the ability to accept both standard Double Open End and Single Open End cartridges, they will suit most applications.

The **65 Series** will accept the full range of Amazon and industry-standard cartridges ranging from 0.1 to 500µm with nominal lengths of 10, 20, 30 and 40".

Product Features

- Dished bottom end allows complete drainage of clean chamber, leading to improved system cleanliness
- Top opening style secured with screw clamps
- Cast compression nut with integral PTFE washer for easy, hand tight cartridge sealing
- Wide range of connection sizes and types, cartridge lengths and materials of construction
- PED and ATEX Compliant

Accessories	Part Number
Pressure Gauge and Vent Valve Kit 	60S000016
Pressure Gauge and Auto Vent Valve Kit 	60S000082
Ball Valve and Nipple 	60S000010



Features and Benefits

- Integral vent, clean and dirty drains to aid efficient filter change-out
- Each housing hydrostatically pressure tested
- Internally and externally electropolished as standard
- Each housing is etched with a unique serial number for full traceability
- Full housing customisation service available
- Universal cup enables choice of plug-in (Code 3 and Code 8) or DOE cartridge styles in the same housing

Product Range

Amazon Filters design and manufacture an extensive range of liquid filtration systems, providing one of the widest selections of filtration vessels, depth filters and pleated cartridges available today, ensuring excellent process and filter compatibility. As one of Europe's leading manufacturers of filtration systems, Amazon Filters is able to offer a solution to meet all filtration requirements. Amazon's filters are manufactured in clean room conditions and all products come with detailed Product Validation Guides and Technical Support documentation.



65 Series Technical Data

Max Operating Conditions	6503	6505	6510
Liquid: Bolted closure:	FV/16 bar g	FV/16 bar g	FV/16 bar g
Gas: Bolted closure:	FV/16 bar g	FV/16 bar g	FV/1.5 bar g
Temperature Range:	-10°C / 150°C		

Materials of Construction

Body:	316L St. Steel		
Closure:	Screw Clamp - Zinc-plated carbon steel (Optional Stainless Steel)		
Vessel Finish:	Electropolished		

Connections

	6503	6505	6510
Inlet/Outlet:	2" BSPM	2" BSPM	3" Flange
Vent:	¼" BSP	¼" BSP	½" BSP
Drain:	½" BSPM	½" BSPM	½" BSPM

PED Status:

Fluid Groups:	Compliant with 2014/68/EU Liquids Group 1 + 2 Gas Group 1 + 2
Marking:	CE Marked
Exceptions:	Group 1 liquids - Explosive

ATEX:

Compliant with 2014/34/EU, level CE Ex II 2 GD c X

Technical drawings for each individual housing showing dimensions, volume, weights, maximum temperatures and design pressures available on request.

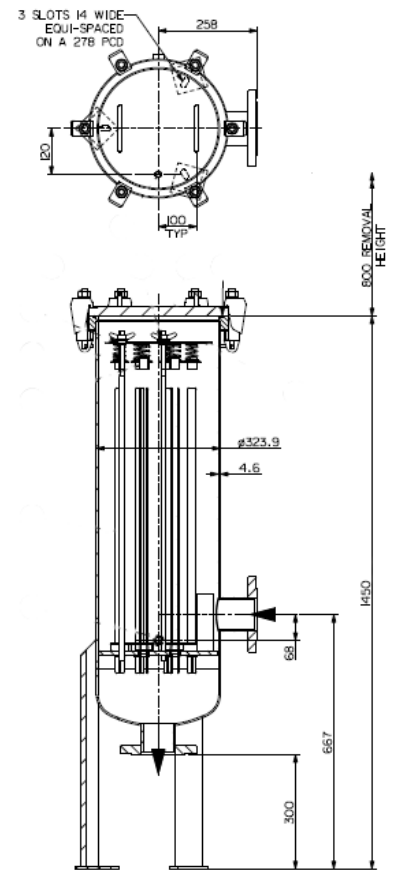

BÈTA
industrie

WWW.BETA-INDUSTRIE.NL
TEL: 0031-79-3415518

AMAZON FILTERS LTD.

ALBANY PARK ESTATE, FRIMLEY ROAD
CAMBERLEY, SURREY, GU16 7PG
ENGLAND

Tel. +44 (0) 1276 670600
Fax. +44 (0) 1276 670101
Email. sales@amazonfilters.co.uk
Web. www.amazonfilters.com